



RANGE OF PERFORMANCE

Flow rate up to 400 l/min (24 m³/h)
Head up to 14.5 m

LIMITS OF USE

Depth up to 5 metres (3 metres up to 0.55 kW)
Liquid temperature up to + 40°C
(+90°C for a maximum period of 3 minutes)
Passage of solid bodies up to Ø 10 mm
Drainage level:
14 mm from the bottom for SPEED 30-50-70M
30 mm from the bottom for SPEED 100-125M

INSTALLATION AND USE

THE SPEED SERIES IS SUITABLE FOR DRAINING CLEAR WATER WITHOUT ABRASIVE PARTICLES. THE CONSTRUCTION GUARANTEES SIMPLE AND SAFE OPERATION DUE TO THE COMPLETE COOLING OF THE MOTOR BY THE PUMPED WATER AND THE DOUBLE SEAL DESIGN. THEY ARE RECOMMENDED FOR EMERGENCY DRAINING OF SMALL FLOODED AREAS (ROOMS, CELLARS, GARAGES), FOR THE DISPOSAL OF WASTE WATER IN THE HOME (DISHWASHER, WASHING MACHINE) AND FOR EMPTYING DRAINAGE TRAPS.

GUARANTEE 2 YEARS subject to our general terms of sale.

CONSTRUCTION CHARACTERISTICS

• **DELIVERY BODY:** glass filled **technopolymer**,

particularly resistant to impact and corrosion, with threaded port ISO 228/1.

- **SUCTION GRID:** technopolymer.
 - **IMPELLER:** open type in **technopolymer**.
 - **MOTOR SUPPORT:** stainless steel AISI 304.
 - **MOTOR SHAFT:** stainless steel EN 10088-3 - 1.4104.
 - **DOUBLE SEAL:** **mechanical seal ceramic - graphite - NBR**, with oil barrier chamber and inner lip seal to protect the seal in the event of dry running.
 - **MOTOR:** submersible asynchronous single-phase for continuous duty.
- SPEED M:** single-phase 220±240 V - 50 Hz with capacitor and thermal overload protector built into the winding.
- **INSULATION:** class F.
 - **PROTECTION:** IP 68.

STANDARD FEATURES:

SPEED 30-50-70 M (single-phase)

- Float switch.
- Hosetail.
- Power cable in neoprene "H05RN-F" length **5 metres** with Schuko plug.

SPEED 100-125 M (single-phase)

- Float switch.
- Hosetail.
- Coupling with flap valve.
- Neoprene power cable "H05 RN-F" length **10 metres** with Schuko plug.

OPTIONS ON REQUEST

⇒ pumps for aggressive liquids **SPEED - AF**

- ⇒ special mechanical seal
- ⇒ 10 metres power cable. N.B. required for outdoor use to comply with standard EN 60335-2-41
- ⇒ versions without float switch
- ⇒ other voltages or frequency 60 Hz

CONSTRUCTION AND SAFETY STANDARDS

EN 60 335-1

EN 60034-1

IEC 335-1

IEC 34-1

CEI 61-150

CEI 2-3



DIMENSIONS

Typical portable application

SPEED-AF*
for aggressive liquids

TYPE
Single-phase
SPEED 30M - AF
SPEED 50M - AF
SPEED 70M - AF
SPEED 100M - AF
SPEED 125M - AF

* Wetted metal parts in AISI 316 stainless steel.

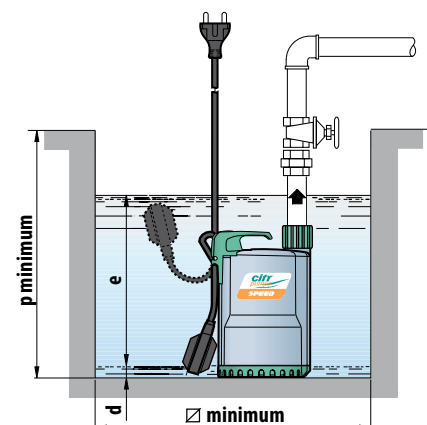
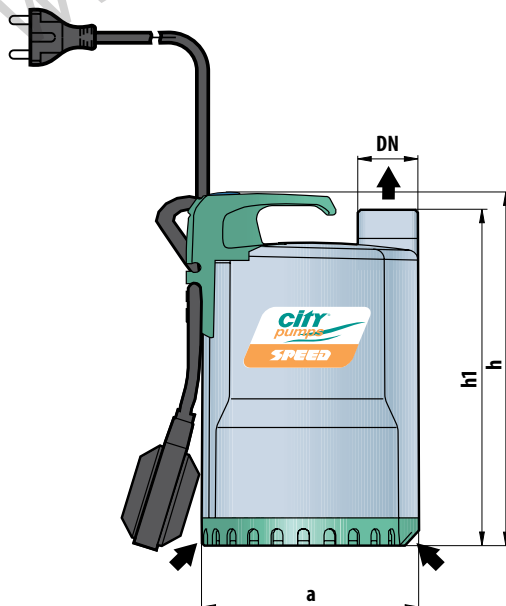



SPEED

DRAINAGE submersible pumps

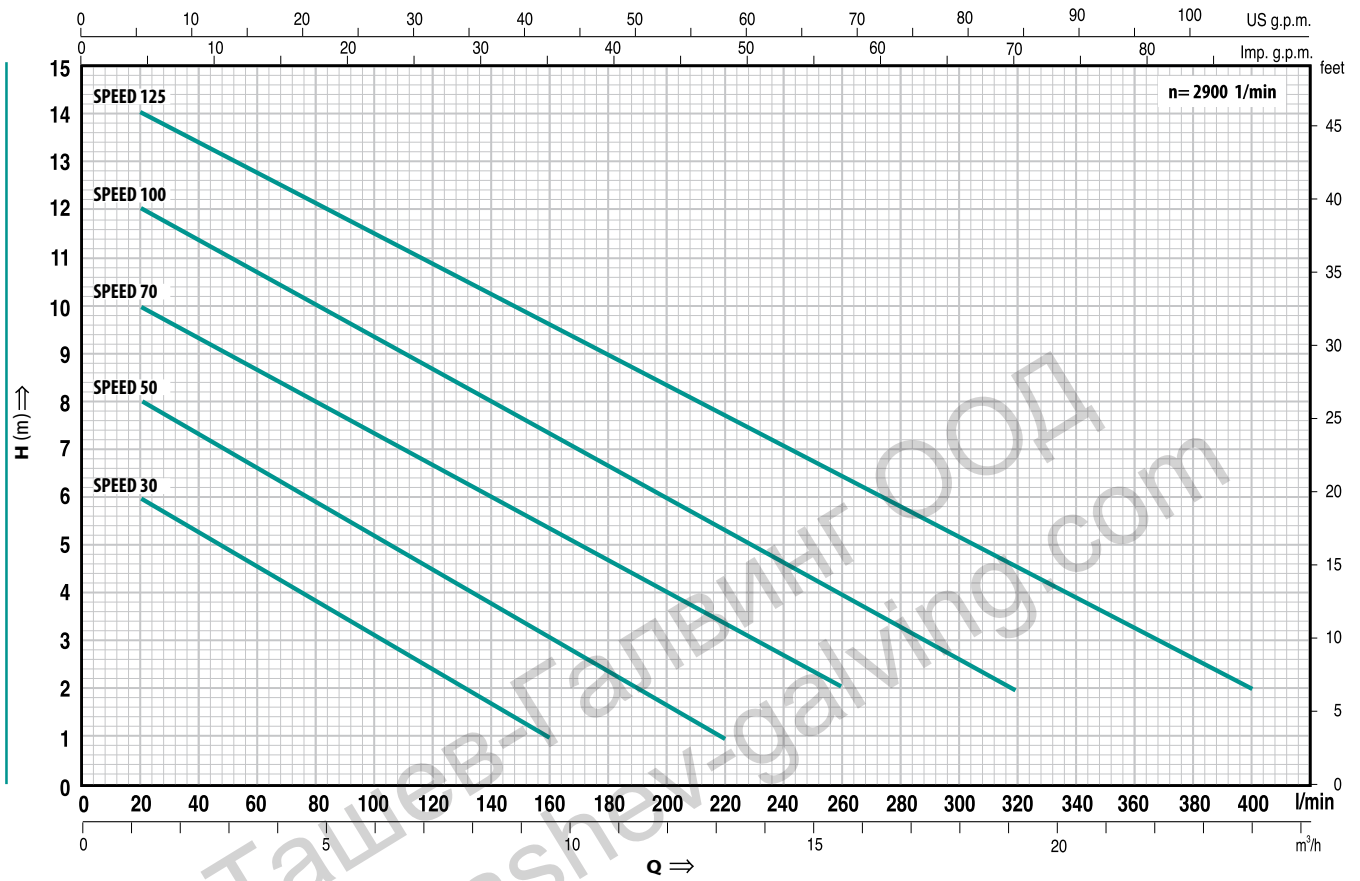

Q = Flow rate H = Total manometric head

Tolerance of the performance curves according to EN ISO 9906 App. A.

TYPE	POWER		m³/h l/min	H metres																							
	kW	HP		0	1.2	2.4	3.6	4.8	6.0	7.2	8.4	9.6	10.8	12	13.2	14.4	15.6	16.8	18.0	19.2	20.4	21.6	22.8	24			
Single-phase			0	20	40	60	80	100	120	140	160	180	200	220	240	260	280	300	320	340	360	380	400				
SPEED 30M	0.25	0.33	7	6	5.5	4.5	4	3	2.5	1.5	1																
SPEED 50M	0.37	0.50	9	8	7.5	6.5	6	5.5	4.5	4	3	2.5	1.8	1													
SPEED 70M	0.55	0.75	10.5	10	9	8.8	8	7.5	6.5	6	5.5	4.8	4	3.5	2.5	2											
SPEED 100M	0.75	1	12.6	12	11.5	10.7	10	9.3	8.7	8	7.3	6.7	6	5.3	4.7	4	3.3	2.7	2								
SPEED 125M	0.92	1.25	14.5	14	13.5	12.7	12.1	11.5	10.8	10.2	9.6	8.9	8.3	7.7	7.1	6.4	5.8	5.2	4.5	3.9	3.3	2.6	2				

DIMENSIONS AND WEIGHTS

TYPE	PORT DN	DIMENSIONS mm							kg
		a	h	h1	d	e	p	∅	
SPEED 30M	1"	152	232	217	14	adjustable	350	350	4.1
SPEED 50M	1 1/4"		257	237					5.0
SPEED 70M	1 1/4"		287	267					6.4
SPEED 100M	1 1/2"	204	334	310	21		450	450	9.8
SPEED 125M									10.8